

Crane control unit

KST 5 swiveling



The KST 5 is an ergonomically designed swiveling crane control chair which provides a high degree of comfort.

Equipment boxes:

The equipment boxes are made from sheet steel and as standard have a hinged lid with locking feature. This allows for easy inspection and maintenance. The side of the equipment boxes is as standard fitted with an inspection plate which again is lockable. The arrangement of the joystick, indicators and control devices is customised according to customer specifications. This combined with the custom sized and profiled equipment boxes that are available means that the KST 5 is very flexible and customisable solution.

Driver seat:

As standard the KST 5 is fitted with a KFS 11 seat. The seat itself is fitted with a hydraulic vibration absorption system complete with weight adjustment to ensure that the comfort level is fitted with armrests and a headrest. There is the option to have the seat covered with air-permeable artificial leather.

Cross-member with swivel base:

The cover of the sheet steel cross-member including the driver's seat is forward foldable.

Thereby all wirings, terminals and bushings are easily accessible during commissioning and maintenance.

Swivel base has zero-clearance bearing and can be locked by a friction brake.

Surface treatment:

Base coat and textured varnish
Standard colour RAL 9011 black



Example

KST 51 - 3 - M1 - F1 - LK / KFS 11 / V64 / V64.1 / KL / X

Basic unit

- KST 51 With equipment boxes 200x580mm
 - KST 52 With equipment boxes 270x580mm
 - KST 54 With equipment boxes 320x580mm
- Special boxes for demand!*

Base unit

- 1 Swiveling 180° left, 90° right with friction brake
- 2 Electric swiveling 180° left, 90° right
- 3 Not swiveling

Attachments

- M1 Monitor mounting with monitor housing
- M2 Monitor mounting with monitor mounting bracket
- M3 Monitor mounting without Monitor housing/-mounting bracket
- F1 Footrest KBF/433
- H Heater 2x2kW with ventilator 240V AC
- LS Plate for horizontal manual adjustment for control units +/- 75mm
- LK Plate for horizontal manual adjustment for control units +/- 250mm
- Label without engraving for multi-axis-/ single-axis controller
- Label with engraving for multi-axis-/ single-axis controller

KST 51 - 3 - M1 - F1 - LK / KFS 11 / V64 / V64.1 / KL / X

Driver seat	
KFS 11*	<i>(included in the delivery!)</i>
KFS 9*	
KFS 10*	
KFS 12*	
*Description see driver seat page 187	
Mounting for equipment boxes	
V...	Multi-axis controller <i>(see page 1)</i>
S...	Single-axis controller <i>(see page 71)</i>
D...	Double-handle controller <i>(see page 49)</i>
N...	Control-switch <i>(see page 107)</i>
...	More command and indicating devices <i>(see page 163)</i>
Wiring	
KL	Without, but terminal block built each terminal
KLV	On terminal block 4qmm with single wire 1qmm each terminal
KLVA	On SPS (SPS provision) with single wire 1qmm each terminal
KLVA	External wiring single wire highly flexible 1,5qmm 5m long, each terminal
Special model	
X	Special / customer-specific
X1	Special painted
3 Option	
Radio remote control system	

Crane control unit KST 5 swiveling

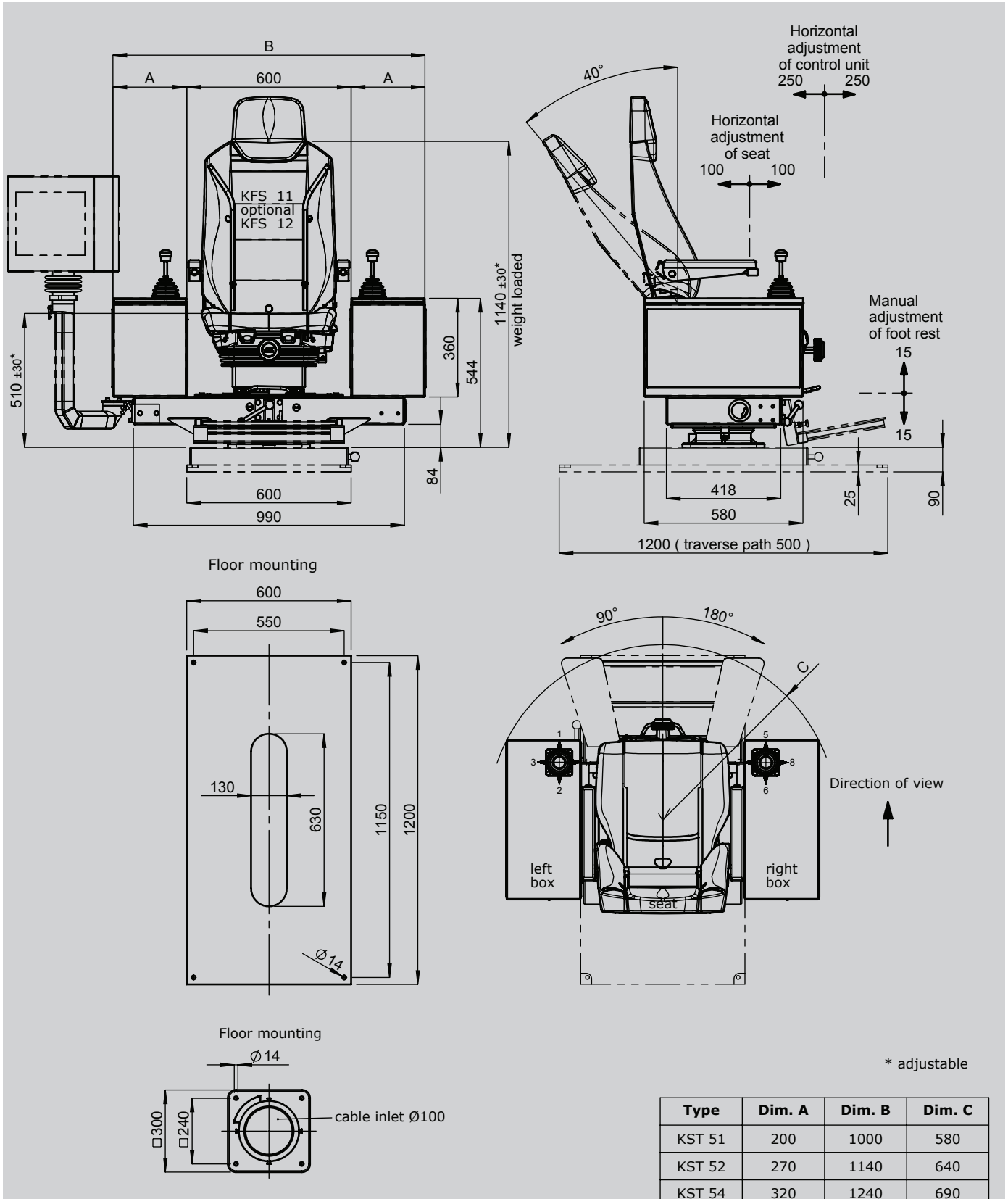

3